

41 WELDING AND CUTTING

Welding is a process which uses heat and/or pressure to join metals.

Arc welding is by far the most commonly used one in construction. Molten metal from the workpiece and a filler metal from an electrode form a common puddle which cools to form a weld.

Flame cutting is an allied process that requires the use of a torch, fuel gas, and oxygen to cut metals—primarily steel.

For some of the information in this chapter, IHSA gratefully acknowledges its use of the Canadian Standards Association standard CAN/CSA-W117.2 *Safety in Welding, Cutting and Allied Processes*, © CSA.

Welding Methods

Shielded Metal Arc Welding (SMAW) is the most common arc welding process in construction (Figure 1).

SMAW uses a short length of consumable electrode which melts as it maintains the arc. Melted metal from the electrode is carried across the arc to become the filler metal of the weld.

The electrode is coated with a complex mix of chemicals that release a shielding gas such as carbon dioxide to keep air out of the arc zone and protect the weld from oxidation. The composition of the coating varies with the metal being welded.

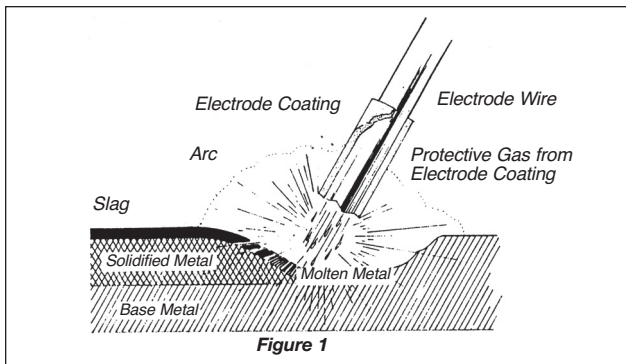

Figure 1

Gas Metal Arc (GMAW) or Metal Inert Gas Welding (MIG) uses an uncoated consumable wire that is fed continuously down the middle of the welding torch. A ring-like tube

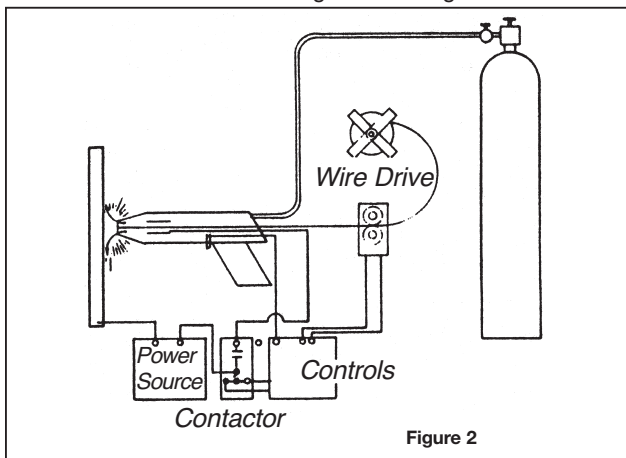

Figure 2

around the wire transports an inert gas such as argon, helium, or carbon dioxide from an outside source to the arc zone to prevent oxidation of the weld (Figure 2).

Flux Cored Arc Welding (FCAW) is a variation of MIG welding. It uses a hollow consumable wire whose core contains various chemicals that generate shielding gases to strengthen the weld (Figure 3).

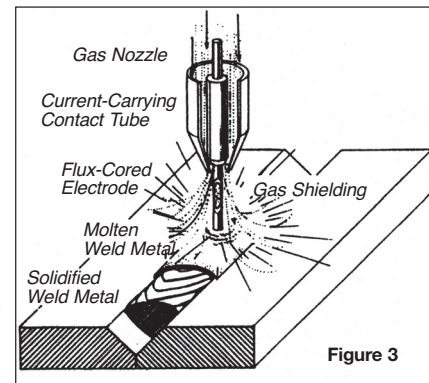

Figure 3

Gas Tungsten

Arc Welding (GTAW) or Tungsten Inert Gas Welding (TIG) uses a non-consumable tungsten electrode that maintains the arc and provides enough heat to join metals (Figure 4). Filler metal is added in the form of a rod held close to the arc. The rod melts and deposits filler metal at the weld. Shielding gases may or may not be used, depending on the metal being welded.

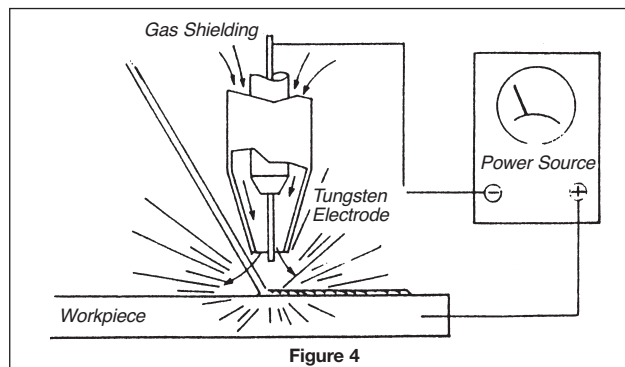

Figure 4

Oxyacetylene Welding and Cutting burns a mixture of gases—oxygen and acetylene—to generate heat for welding metals (Figure 5). It's the most common fuel gas cutting and welding used in construction. The process may also employ the use of a filler metal.

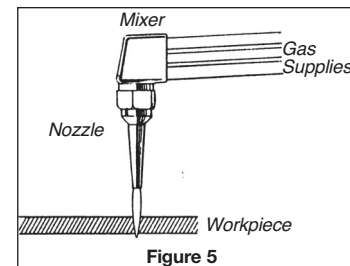

Figure 5

ACETYLENE

Acetylene is a mixture of carbon and hydrogen. Its stored energy is released as heat when it burns. When burned with oxygen, acetylene can produce a higher flame temperature (3,300°C) than any other gas used commercially. The wide flammable range of acetylene (2.5% to 81% in air) is greater than that of other commonly used gases, with consequently greater hazard.

OTHER FUEL GASES

Fuel gases for welding are used alone or with oxygen. Examples include propane, propylene, and natural gas.

Types of Base Metals Welded

Mild Steel (an alloy of iron, carbon, silicon, and occasionally molybdenum or manganese).

Stainless and High Alloy Steels (containing iron, nickel, chromium, and occasionally cobalt, vanadium, manganese, and molybdenum).

Aluminum (either pure or as an alloy containing magnesium, silicon, and occasionally chromium).

Galvanized steel (steel that has been coated with a layer of zinc to prevent corrosion).

Welding Hazards

Welders in construction are exposed to a wide range of hazards such as inhalation of toxic fumes and gases, serious burns from hot metal, and electric shocks from welding cable.

Welding Hazards

- Physical**
 - ionizing radiation (x-rays, gamma rays)
 - non-ionizing radiation (ultraviolet, infrared)
 - visible light
 - temperature extremes
 - noise
 - electrical energy
- Chemical**
 - flammable/combustible products
 - welding fumes
 - toxic gases
 - dust
- Biological**
 - bacteria
 - fungi
 - viruses

Eye protection is a must for welders and others who may be exposed to the welding process.

Once a chemical from welding has entered the body it may have a toxic effect. Effects can range from mild irritation to death and are influenced by a number of factors. Different organs may also be affected, such as the lungs, kidneys, and brain.

The two major types of effects are acute and chronic, as described in the Basic Occupational Health chapter in this manual.

PHYSICAL HAZARDS

Radiation

Both ionizing and non-ionizing radiation may be encountered by welders and their helpers. Ionizing is more hazardous because it can contribute directly to cancer.

Ionizing — A common source is the emission of x-rays and gamma rays from equipment used to gauge the density and thickness of pipes and to check welds.

Non-ionizing — A major source is ultraviolet, infrared, and visible light radiation from sunlight or welding.

Radiation produced by the welding process is mainly non-ionizing, which includes electromagnetic fields, infrared radiation, visible light, and ultraviolet radiation.

Exposure to ultraviolet (UV) radiation can result directly from the arc or from a reflection off bright objects such as shiny metal or white clothing. It can cause “arc eye” when sight is not adequately protected. Eyes become watery and painful anywhere from 2 to 24 hours after exposure. The condition may last 1–5 days but is usually reversible with no lasting effects. However, repeated exposure may result in scar tissue that can impair vision.

UV exposure may also cause a temporary loss of visual sharpness called “fluorescence.”

Skin reddening, commonly known as sunburn, is another hazard of UV exposure. Blistering may occur in extreme cases. Although excessive exposure to UV radiation from the sun has been linked to skin cancer, there are no reports of increased skin cancer rates from welding exposure.

The intensity of UV radiation varies with the type of welding. Generally, the higher the temperature of the welding process the higher the UV radiation.

Infrared radiation is hazardous for its thermal or heating effects. Excessive exposure to the eye may cause damage.

Visible light is released at high intensity by welding. Short-term exposure can produce “flash blindness” in which vision is affected by after-images and temporary blind spots. Repeated exposure to high-intensity visible light can produce chronic conjunctivitis, characterized by red, tearful eyes.

X-rays and gamma rays are invisible forms of *ionizing* radiation used to inspect welds and can be extremely damaging to unprotected parts of the body. Keep well away from any area where this type of testing is under way. X-rays are also produced during electron beam welding. The welding chamber must be completely shielded to confine the x-rays and protect the operator.

Extreme Temperatures

Very high temperatures are caused by the welding process. Gas flames may reach 3,300°C. Metals melt in a range from 260°C to 2,760°C. Welded materials, the work environment, and weather may all be sources of excessive heat which can cause muscle cramps, dehydration, sudden collapse, and unconsciousness.

Welders may suffer frostbite and hypothermia when working in extreme cold climates or with welding gases stored at temperatures as low as -268°C. Exposure to freezing temperatures can lead to fatigue, irregular breathing, lowered blood pressure, confusion, and loss of consciousness. Heat stress and cold stress are both life-threatening and, if not treated in time, can be fatal.

Noise

Sound waves over 85 dBA emitted at high intensity by welding equipment can lead to hearing loss. Noise has also been linked to headaches, stress, increased blood pressure, nervousness, and excitability. (See the chapter on “Hearing Protection” for information on maximum exposures for workers not equipped with hearing protection.)

Welding noise is produced by the power source, the welding process, and by secondary activities such as

grinding and hammering. Gasoline power sources may lead to sound exposures over 95 dBA. Arc gouging may produce sound levels over 110 dBA. Grinding, machining, polishing, hammering, and slag removal all contribute to high levels of noise. Substantial hearing loss has been observed in welders.

Electrical Energy

Electrical shock is the effect produced by current on the nervous system as it passes through the body. Electrical shock may cause violent muscular contractions, leading to falls and injuries. It may also have fatal effects on the heart and lungs.

Electrical shock may occur as a result of improper grounding and/or contact with current through damp clothing, wet floors, and other humid conditions. Even if the shock itself is not fatal, the jolt may still cause welders to fall from their work positions.

Electrical burns are an additional hazard. The burns often occur below the skin surface and can damage muscle and nerve tissue. In severe cases, the results can be fatal.

The extent of injury due to electrical shock depends on voltage and the body's resistance to the current passing through it (see the Electrical Hazards chapter in this manual). Even low voltages used in arc welding can be dangerous under damp or humid conditions. Welders should keep clothing, gloves, and boots dry and stay well insulated from work surfaces, the electrode, the electrode holder, and grounded surfaces.

Stray Current

Stray welding current may cause extensive damage to equipment, buildings, and electrical circuits under certain conditions.

CHEMICAL HAZARDS

Chlorinated solvents for degreasing, zinc chromate-based paint for anti-corrosion coatings, cadmium or chromium dusts from grinding, and welding fumes are all classified as chemical hazards.

Arc welders are at particular risk since the high temperatures generated by the arc can release heavy concentrations of airborne contaminants.

Chemical hazards may injure welders through inhalation, skin absorption, ingestion, or injection into the body. Damage to respiratory, digestive, nervous, and reproductive systems may result. Symptoms of overexposure to chemicals may include nosebleeds, headaches, nausea, fainting, and dizziness.

Read the manufacturer's material safety data sheet (MSDS) for information on protective measures for any chemical you encounter in the workplace.

The most common chemical hazards from welding are airborne contaminants that can be subdivided into the following groups:

- fumes
- gases/vapours
- dusts.

The amount and type of air contamination from these sources depends on the welding process, the base metal,

and the shielding gas. Toxicity depends on the concentration of the contaminants and the physiological response of individual workers.

Fumes

Some of the metal melted at high temperatures during welding vaporizes. The metal vapour then oxidizes to form a metal oxide. When this vapour cools, suspended solid particles called fume particles are produced. Welding fumes consist primarily of suspended metal particles invisible to the naked eye.

Metal fumes are the most common and the most serious health hazard to welders. Fume particles may reach deep into the lungs and cause damage to lung tissue or enter the bloodstream and travel to other parts of the body. The following are some common welding fumes.

Beryllium is a hardening agent found in copper, magnesium, and aluminum alloys. Overexposure may cause *metal fume fever*. Lasting for 18–24 hours, the symptoms include fever, chills, coughing, dryness of mouth and throat, muscular pains, weakness, fatigue, nausea, vomiting, and headaches. Metal fume fever usually occurs several hours after the exposure and the signs and symptoms usually abate 12–24 hours after the exposure with complete recovery. Immunity is quickly acquired if exposure occurs daily, but is quickly lost during weekends and holidays. For this reason, metal fume fever is sometimes called "Monday morning sickness."

Long-term (chronic) exposure to beryllium fumes can result in respiratory disease. Symptoms may include coughing and shortness of breath. Beryllium is a suspected carcinogen—that is, it may cause cancer in human tissue. It is highly toxic. Prolonged exposure can be fatal.

Cadmium-plated or cadmium-containing parts resemble, and are often mistaken for, galvanized metal. Cadmium coatings can produce a high concentration of cadmium oxide fumes during welding. Cadmium is also found in solders (especially silver solder) and brazes.

Overexposure to cadmium can cause metal fume fever. Symptoms include respiratory irritation, a sore, dry throat, and a metallic taste followed by cough, chest pain, and difficulty in breathing. Overexposure may also make fluid accumulate in the lungs (pulmonary edema) and may cause death. The liver, kidneys, and bone marrow can also be injured by the presence of this metal.

Chromium is found in many steel alloys. Known to be a skin sensitizer, it may cause skin rashes and skin ulcers with repeated exposure. Chromium also irritates mucous membranes in areas such as eyes and nose and may cause perforation of the nasal septa. Inhaled chromium may cause edema and bronchitis.

Lead can be found in lead-based paints and some metal alloys. Lead poisoning results from inhalation of lead fumes from these lead-based materials. The welding and cutting of lead or lead-coated materials is the primary source of lead poisoning for welders. Symptoms include loss of appetite, anemia, abdominal pains, and kidney and nerve damage. Under Ontario law, lead is a **designated substance** requiring special precautions for use and handling.

Nickel is found in many steel alloys including stainless steel and monel. It is a sensitizing agent and in certain

forms is toxic and carcinogenic. Nickel fumes can also produce cyanosis, delirium, and death 4 to 11 days after exposure.

Zinc is found in aluminum and magnesium alloys, brass, corrosion-resistant coatings such as galvanized metal, and brazing alloys. Inhaling zinc fumes during the cutting or welding of these metals may cause metal fume fever.

Vapours/Gases

A gas is a low-density chemical compound that normally fills the space in which it is released. It has no physical shape or form. Vapour is a gas produced by evaporation.

Several hazardous vapours and gases may be produced by welding. Ultraviolet radiation, surface coatings, shielding gases, and rod coatings are primary sources of vapours and gases. Overexposure may produce one or more of the following respiratory effects:

- inflammation of the lungs
- pulmonary edema (fluid accumulation in the lungs)
- emphysema (loss of elasticity in lung tissue)
- chronic bronchitis
- asphyxiation.

Hydrogen fluoride (HF) gas can be released by the decomposition of rod coatings during welding and irritates the eyes and respiratory system. Overexposure can injure lungs, kidney, liver, and bones. Continued low-level exposures can result in chronic irritation of nose, throat, and bronchial tubes.

Nitrogen oxide (NOx) gas is released through a reaction of nitrogen and oxygen promoted by high heat and/or UV radiation. It is severely irritating to the mucous membranes and the eyes. High concentrations may produce coughing and chest pain. Accumulation of fluid in the lungs can occur several hours after exposure and may be fatal.

Ozone gas is formed by the reaction of oxygen in air with the ultraviolet radiation from the welding arc. It may be a problem during gas-shielded metal arc welding in confined areas with poor ventilation. Overexposure can result in an accumulation of fluid in the lungs (pulmonary edema) which may be fatal.

Phosgene gas is formed by the heating of chlorinated hydrocarbon degreasing agents. It is a severe lung irritant and overexposure may cause excess fluid in the lungs. Death may result from cardiac or respiratory arrest. The onset of symptoms may be delayed for up to 72 hours.

Phosphine or hydrogen phosphide is produced when steel with a phosphate rustproofing coating is welded. High concentrations irritate eyes, nose, and skin.

Asphyxiants are chemicals which interfere with the transfer of oxygen to the tissues. The exposed individual suffocates because the bloodstream cannot supply enough oxygen for life. There are two main classes of asphyxiants—simple and chemical.

Simple asphyxiants displace oxygen in air, thereby leaving little or none for breathing. In welding, simple asphyxiants include commonly used fuel and shielding gases such as acetylene, hydrogen, propane, argon, helium, and carbon dioxide. When the normal oxygen level of 21% drops to 16%, breathing as well as other problems begin, such as

lightheadedness, buzzing in the ears, and rapid heartbeat. Chemical asphyxiants interfere with the body's ability to transport or use oxygen. Chemical asphyxiants can be produced by the flame-cutting of metal surfaces coated, for instance, with rust inhibitors. Hydrogen cyanide, hydrogen sulphide, and carbon monoxide are examples of chemical asphyxiants—all highly toxic.

Dusts

Dusts are fine particles of a solid which can remain suspended in air and are less than 10 micrometres in size. This means they can reach the lungs. Dusts may be produced by fluxes and rod coatings which release phosphates, silicates, and silica. The most hazardous of these is silica which can produce silicosis—a disease of the lung which causes shortness of breath.

BIOLOGICAL HAZARDS

Biological hazards are a relatively minor concern for construction welders. However, exposure to bacteria may occur in sewer work, while air handling systems contaminated by bacteria and fungi can cause legionnaires' disease and other conditions. A fungus that grows on bird or bat droppings is responsible for a disease called histoplasmosis, producing flu-like symptoms. Contact may occur where buildings contaminated with droppings are being renovated or demolished.

Fires/Explosions

There is always a threat of fire with welding. Fires may result from chemicals reacting with one another to form explosive or flammable mixtures. Many chemicals by themselves have low ignition points and are subject to burning or exploding if exposed to the heat, sparks, slag, or flame common in welding. Even sparks from cutting and grinding may be hot enough to cause a fire.

In welding, oxygen and acetylene present the most common hazards of fire and explosion.

Pure oxygen will not burn or explode but supports the combustion of other materials, causing them to burn much more rapidly than they would in air.

Never use oxygen to blow dust off your clothing. Oxygen will form an explosive mixture with acetylene, hydrogen, and other combustible gases.

Acetylene cylinders are filled with a porous material impregnated with acetone, the solvent for acetylene. Because acetylene is highly soluble in acetone at cylinder pressure, large quantities can be stored in comparatively small cylinders at relatively low pressures.

Preventive Measures

Welding hazards must be recognized, evaluated, and controlled to prevent injury to personnel and damage to property.

The WHMIS chapter in this manual explains the information on hazardous materials that can be provided by WHMIS symbols, labels, and material safety data sheets.

Once a welding hazard has been identified, controls can be implemented at its source, along its path, or at the worker.

EXPOSURE FACTORS

Types and effects of airborne contaminants produced by welding depend on the working environment, the kind of welding being done, the material being welded, and the welder's posture and welding technique.

The **environment** for welding is a very important factor in the degree of exposure to fumes, vapours, and gases. Welding is best done outside or in open areas with moderate air movement. Air movement is necessary to dissipate fumes before they reach the welder. Enclosed areas with little ventilation can lead to very high exposure levels because the contaminant is not dispersed. In confined spaces, fume, vapour, and gas levels that are dangerous to life and health may result. Welding may also use up the oxygen in a confined space, causing the welder to lose unconsciousness or even die.

The **base metal** to be welded is an important factor in the production of fumes, vapours, and gases. The base metal will vaporize and contribute to the fume.

Coatings such as rust inhibitors have been known to cause increased fume levels which may contain toxic metals. All paints and coatings should be removed from areas to be welded as they can contribute to the amount and toxicity of the welding fume.

Welding rod is responsible for up to 95% of the fume. Rods with the fewest toxic substances can't always be used because the chemistry of the rod must closely match that of the base metal.

Shielding gas used during SMAW can effect the contaminants produced. Using a mixture of argon and carbon dioxide instead of straight carbon dioxide has been found to reduce fume generation by up to 25%. Nitric oxide in the shielding gas for aluminum during GMAW has been found to reduce ozone levels.

Welding process variables can have a big effect on the fume levels produced. Generally, fume concentrations increase with higher current, larger rods, and longer arc length. Arc length should be kept as short as possible while still producing good welds. Polarity is also a factor. Welding with reversed polarity (work piece negative) will result in higher fumes than welding with straight polarity (work piece positive).

The welder's **posture and technique** are crucial factors in influencing exposure. Studies have shown that different welders performing the exact same task can have radically different exposures. Welders who bend over close to the welding location, those who position themselves in the smoke plume, and those who use a longer arc than required will have a much greater exposure. The welder should try to take advantage of existing ventilation (cross drafts, natural, or mechanical) to direct the plume away from the breathing zone.

VENTILATION

Ventilation is required for all cutting, welding, and brazing. Adequate ventilation is defined as the use of air movement to

- reduce concentrations of airborne contaminants below the acceptable limits in the worker's breathing zone and the work area

- prevent the accumulation of combustible gases and vapours, and
- prevent oxygen-deficient or oxygen-enriched atmospheres.

You need to take special steps to provide ventilation

- in a space of less than 283 cubic metres per welder
- in a room with a ceiling of less than 4.9 metres
- in confined spaces or where the area contains partitions or other structures which significantly obstruct cross-ventilation.

Natural dilution ventilation — welding outside in a light breeze or inside with doors and windows open provides large volumes of fresh air which should disperse airborne contaminants sufficiently in most cases. However, it is important for the welder to stay to one side of the plume.

Natural dilution ventilation alone should not be used for welding, cutting, and allied processes in confined spaces or spaces containing structural barriers that restrict natural air movement.

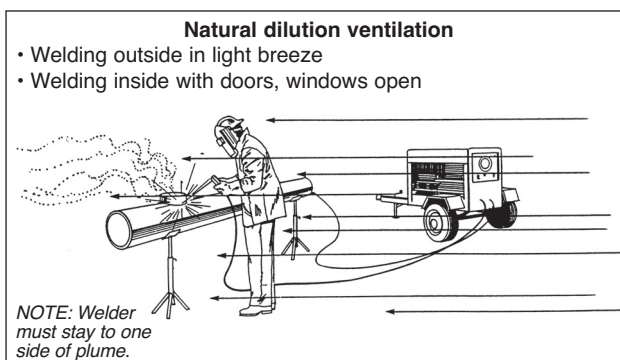

Mechanical dilution ventilation is common in most welding shops. Fans such as roof exhaust fans and wall fans force outside air into and out of the building. General mechanical ventilation in most cases will deflect the plume out of the welder's breathing zone. Welders need different amounts of fresh-air ventilation depending on the specific task and the size of rod they're using. For air volume recommendations, see the American Conference of Governmental Industrial Hygienists' *Industrial Ventilation: A Manual of Recommended Practice*.

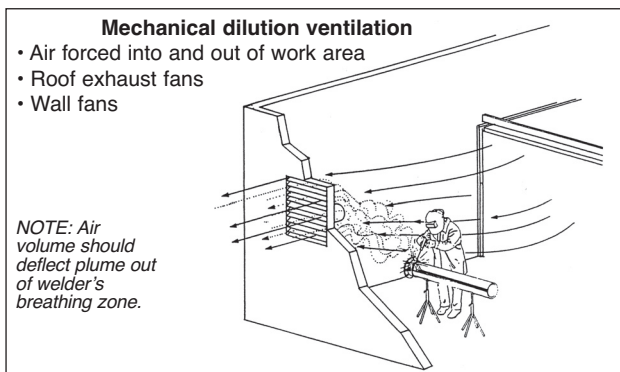

Local exhaust ventilation consists of an exhaust fan, air cleaner, and ducted system dedicated to removing airborne contaminants at the source and exhausting them outdoors. Local exhaust ventilation is preferred over dilution ventilation because it is better able to prevent

airborne contaminants from entering the welder's breathing zone.

Local exhaust ventilation is recommended for welding where toxic airborne contaminants are produced and/or where a high rate of fume is produced—for instance, during GMAW in confined areas with little ventilation where the shielding gases can build up to toxic levels.

There are three types of local exhaust ventilation systems for welding:

- 1) portable fume extractor with flexible ducting (Figure 6)
- 2) fume extraction gun (Figure 7)
- 3) welding bench with portable or fixed hood (Figure 8).

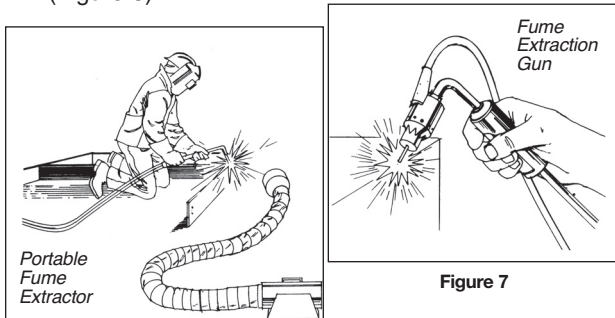

Figure 6

Figure 7

Local Exhaust Systems

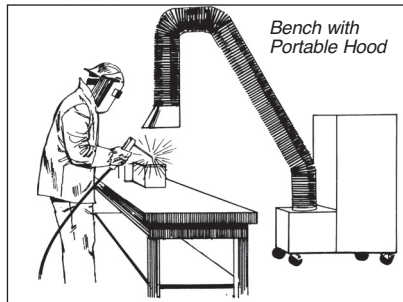

Figure 8

The effectiveness of local exhaust ventilation depends on the distance of the hood from the source, air velocity, and hood placement. Hoods should be located close to the source of airborne contaminants. The hood is placed above and to the side of the arc to capture airborne contaminants.

Warning: In all processes that use shielding gas, air velocities in excess of 30 metres/minute may strip away shielding gas.

Ventilation Requirements

There are two methods for determining ventilation requirements.

One uses air sampling to measure the welder's exposure to airborne contaminants and to determine the effectiveness of the ventilation provided. Monitoring is not well suited to construction because site conditions are constantly changing.

The other method uses tables to select the type of ventilation according to the process, materials, production level, and degree of confinement used in the welding operation.

Ventilation guidelines for different welding processes are spelled out in Canadian Standards Association standard CAN/CSA-W117.2 *Safety in Welding, Cutting and Allied Processes*, © CSA.

Other Controls

An isolation chamber is a metal box with built-in sleeves and gloves. The work is welded inside the box and viewed through a window. This method is used to weld metals that produce extremely toxic fumes. The fumes are extracted from the isolation chamber and ducted outdoors.

Respiratory protection

will not be required for most welding operations if proper ventilation is provided. However, when ventilation or other measures are not adequate, or when the welding process creates toxic fumes (as with stainless steel and beryllium), respiratory protection must be worn.

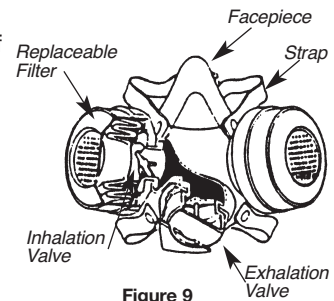

Figure 9

Select respiratory protection based on estimated exposure and the toxicity of the materials. Disposable fume respirators are adequate for low fume levels and relatively non-toxic fumes. For higher exposures or for work involving toxic fumes, a half-mask respirator with cartridges suitable for welding fume should be used (Figure 9).

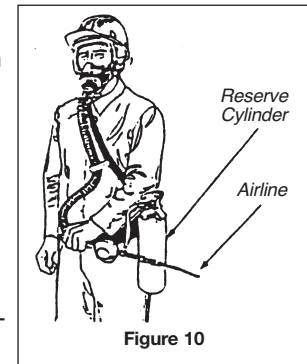

Figure 10

In areas where fume or gas concentrations may be immediately dangerous to life and health, a self-contained breathing apparatus (SCBA) or a supplied-air respirator with a reserve cylinder should be used (Figure 10). Use only supplied air or self-contained respirators in areas where gases may build up or where there can be a reduction in oxygen.

A welder required to wear a respirator must be instructed in its proper fitting, use, and maintenance. For more information, refer to the Respiratory Protection chapter of this manual.

FIRE PREVENTION

Sparks and slag from cutting, grinding, and welding can travel great distances and disappear through cracks in walls and floors or into ducts. They may contact flammable materials or electrical equipment. Fires have started in smoldering materials that went undetected for several hours after work was done.

Take the following steps to prevent fires and explosions.

- Obtain a hot work permit through the safety officer if required.
- Keep welding area free of flammable and explosive material.

- Use a flammable gas and oxygen detector to determine whether a hazardous atmosphere exists.
- Provide fire barriers such as metal sheets or fire blankets and fill cracks or crevices in floors to prevent sparks and slag from passing through.
- Provide fire extinguishers suitable for potential types of fire. Know where the extinguishers are and how to use them.
- Provide a firewatch where necessary—a worker to watch for fires as the welder works and for at least thirty minutes afterward. The person must be fully trained in the location of fire alarms and the use of fire-fighting equipment. Some situations may require more than one firewatch, such as on both sides of a wall or on more than one floor.

Cutting torches should be equipped with reverse flow check valves and flame arrestors to prevent flashback and explosion (Figure 11). These valves must be installed according to the manufacturer's instructions.

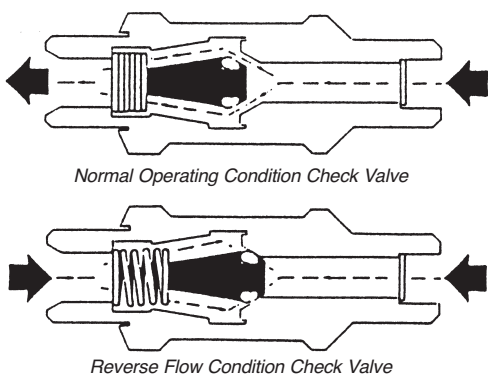

Figure 11

Drums, tanks, and closed containers that have held flammable or combustible materials should be thoroughly cleaned before welding or cutting. As an added precaution, purge with an inert gas such as nitrogen or carbon dioxide and fill with water to within an inch or two of the place to be welded or cut and vent to atmosphere (Figure 12).

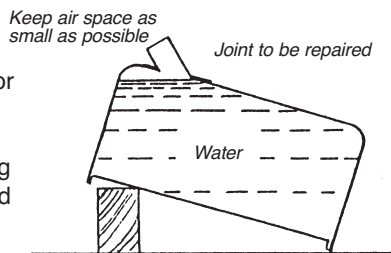

Figure 12

Many containers that have held flammable or combustible materials present special problems. Consult the manufacturer or the product MSDS for detailed information.

Arc Welding and Cutting

EQUIPMENT

Use only manual electrode holders that are specifically designed for arc welding and cutting and can safely handle the maximum-rated current capacity required by the electrodes.

Any current-carrying parts passing through the portion of the holder in the welder or cutter's hand, and the outer

surfaces of the jaws of the holder, should be fully insulated against the maximum voltage encountered to ground.

Arc welding and cutting cables should be completely insulated, flexible, and capable of handling the maximum current requirements of the work as well as the duty cycle under which the welder or cutter is working.

Avoid repairing or splicing cable within 10 feet of the cable end to which the electrode holder is connected. If necessary, use standard insulated connectors or splices which have the same insulating qualities as the cable being used. Connections made with cable lugs must be securely fastened together to give good electrical contact. The exposed parts of the lugs must be completely insulated. Do not use cables with cracked or damaged insulation, or exposed conductors or end connectors.

A welding cable should have a safe current carrying capacity equal to or exceeding the maximum capacity of the welding or cutting machine.

Warning: Never use the following as part of the current path:

- cranes
- hoists
- chains
- wire ropes
- elevator structures
- pipelines containing gases or flammable liquids
- conduits containing electrical circuits.

The work lead, often incorrectly referred to as the ground lead, should be connected as close as possible to the location being welded to ensure that the current returns directly to the source through the work lead.

A structure employed as a work lead must have suitable electrical contact at all joints. Inspect the structure periodically to ensure that it is still safe. Never use any structure as a circuit when it generates arc, sparks, or heat at any point.

The frames on all arc welding and cutting machines must be grounded according to the CSA standard or the regulatory authority. Inspect all ground connections to ensure that they are mechanically sound and electrically adequate for the required current.

PROCEDURES

- When electrode holders are to be left unattended, remove electrode and place holder so it will not make contact with other workers or conducting objects.
- Never change electrodes with bare hands or with wet gloves.
- Do not dip hot electrode holders in water to cool them off.
- Keep cables dry and free of grease to prevent premature breakdown of insulation.
- Cables that must be laid on the floor or ground should be protected from damage and entanglement.
- Keep welding cables away from power supply cables and high tension wires.
- Never coil or loop welding cables around any part of your body.
- Do not weld with cables that are coiled up or on spools. Unwind and lay cables out when in use.

- Before moving an arc welding or cutting machine, or when leaving machine unattended, turn the power supply OFF.
- Report any faulty or defective equipment to your supervisor.
- Read and follow the equipment manufacturer's instructions carefully.
- Prevent shock by using well-insulated electrode holders and cables, dry clothing and gloves, rubber-soled safety boots, and insulating material (such as a board) if working on metal.
- All arc welding and cutting operations should be shielded by non-combustible or flame-proof screens to protect other workers from direct rays of the arc.
- Keep chlorinated solvents shielded from the exposed arc or at least 200 feet away. Surfaces prepared with chlorinated solvents must be thoroughly dry before being welded. This is especially important when using gas-shielded metal-arc welding, since it produces high levels of ultraviolet radiation.
- Check for the flammability and toxicity of any preservative coating before welding, cutting, or heating. Highly flammable coatings should be stripped from the area to be welded. In enclosed spaces, toxic preservative coatings should be stripped several inches back from the area of heat application or the welder should be protected by an airline respirator. In the open air, a suitable cartridge respirator should be used. Generally, with any preservative coating, check the manufacturer's MSDS for specific details regarding toxicity and personal protection required.
- Shut off the power supply before connecting the welding machine to the building's electrical power.

Oxyacetylene Welding and Cutting

HANDLING CYLINDERS

- Do not accept or use any compressed gas cylinder which does not have proper identification of its contents.
- Transport cylinders securely on a hand truck whenever possible. Never drag them.
- Protect cylinders and any related piping and fittings against damage.
- Do not use slings or magnets for hoisting cylinders. Use a suitable cradle or platform (Figure 13).
- Never drop cylinders or let them strike each other violently.
- Chalk EMPTY or MT on cylinders that are empty. Close valves and replace protective caps.
- Secure transported cylinders to prevent movement or upset.
- Always regard cylinders as full and handle accordingly.
- For answers about handling procedures, consult the manufacturer, supplier, or the MSDS.

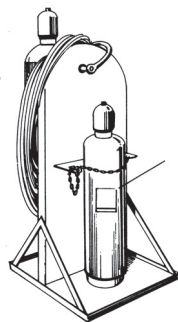

Figure 13

STORING CYLINDERS

- Store cylinders upright in a safe, dry, well-ventilated location maintained specifically for this purpose.

- Never store flammable and combustible materials such as oil and gasoline in the same area.
- Do not store cylinders near elevators, walkways, stairwells, exits, or in places where they may be damaged or knocked over.

- Do not store oxygen cylinders within 20 feet of cylinders containing flammable gases unless they are separated by a partition at least 5 feet high and having a fire-resistance rating of at least 30 minutes (Figure 14).

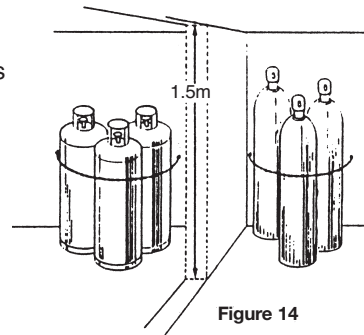

Figure 14

- Store empty and full cylinders separately.
- Prohibit smoking in the storage area.

USING CYLINDERS

- Use oxygen and acetylene cylinders in a proper buggy equipped with a fire extinguisher (Figure 15). Secure cylinders upright.
- Keep the cylinder valve cap in place when the cylinder is not in use.
- Do not force connections on cylinder threads that do not fit.
- Open cylinder valves slowly. Only use the handwheel, spindle key, or special wrench provided by the supplier.
- Always use a pressure-reducing regulator with compressed gases. For more information, see the box below.
- Before connecting a regulator to a cylinder, crack the cylinder valve slightly to remove any debris or dust that may be lodged in the opening. Stand to one side of the opening and make sure the opening is not pointed toward anyone else, other welding operations, or sparks or open flame.
- Open the fuel gas cylinder valve not more than 1½ turns unless marked back-seated.
- Do not use acetylene pressure greater than 15 psig.
- Never allow sparks, molten metal, electric current, or excessive heat to come in contact with cylinders.
- Never use oil or grease as a lubricant on the valves or attachments of oxygen cylinders. Do not handle with oily hands, gloves, or clothing. The combination of oxygen and oil or grease can be highly combustible.
- Never bring cylinders into unventilated rooms or enclosed areas.
- Do not use oxygen in place of compressed air for pneumatic tools.
- Release pressure from the regulator before removing it from the cylinder valve.

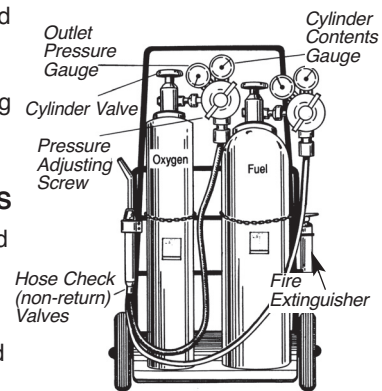

Figure 15

- When gas runs out, extinguish the flame and connect the hose to the new cylinder. Purge the line before re-igniting the torch.
- When work is finished, purge regulators, then turn them off. Use a proper handle or wrench to turn off cylinders.

Pressure Regulators

Pressure regulators must be used on both oxygen and fuel gas cylinders to maintain a uniform and controlled supply of gas to the torch.

The oxygen regulator should be designed with a safety relief valve so that, should the diaphragm rupture, pressure from the cylinder will be released safely and the regulator will not explode.

Each regulator (both oxygen and fuel gas) should be equipped with a high-pressure contents gauge and working pressure gauge. Always stand to one side of regulator gauge faces when opening the cylinder valves.

To prevent regulators from being installed on the wrong cylinders, oxygen cylinders and regulators have *right-hand* threads while most fuel gas cylinders and regulators have *left-hand* threads.

Internal and external threads and different diameters also help to prevent wrong connections.

Hoses and hose connections for oxygen and acetylene should be different colours. Red is generally used to identify the fuel gas and green the oxygen. The acetylene union nut has a groove cut around the centre to indicate left-hand thread.

- Protect hoses from traffic, flying sparks, slag, and other damage. Avoid kinks and tangles.
- Repair leaks properly and immediately. Test for leaks by immersing hose in water.
- Use backflow check valves and flame arrestors according to the manufacturer's instructions (Figure 11).
- Do not use a hose which has been subject to flashback or which shows evidence of wear or damage without proper and thorough testing.

Backfires occur when the flame burns back into the torch tip, usually accompanied by a loud popping sound. Backfires are usually caused by touching the tip against the work or by using pressures that are too low.

Flashback is much more serious. The flame burns back inside the torch itself with a squealing or hissing sound. If this happens, follow the torch manufacturer's instructions to extinguish the torch in proper sequence.

Many different makes, models, and designs of torches are available. There is no single procedure or sequence to follow in igniting, adjusting, and extinguishing the torch flame. Always follow the manufacturer's instructions.

Oxyacetylene Summary

Startup

- Keep cylinders away from sources of heat or damage and secure them upright.
- Stand to one side and slightly crack cylinder valves to blow out dust.

- Attach regulators to respective cylinders. Tighten nuts with a proper wrench.
- Release pressure adjusting screws on regulators.
- Connect green hose to oxygen regulator and red hose to fuel gas regulator.
- Connect hoses to the torch—green to oxygen inlet and red to fuel gas inlet.
- Connect mixer and welding tip assembly to torch handle.
- Open oxygen cylinder valve slowly and fully.
- Open fuel gas cylinder $\frac{3}{4}$ to $1\frac{1}{2}$ turns.
- Open oxygen torch valve. Turn oxygen regulator pressure adjusting screw to desired pressure. Continue oxygen purge for about 10 seconds for each 100 feet of hose. Close oxygen torch valve.
- Open fuel gas torch valve. Turn fuel gas regulator pressure adjusting screw to desired pressure and purge for about 10 seconds for each 100 feet of hose. Close fuel gas torch valve.
- To light torch, follow the manufacturer's instructions. **DO NOT USE MATCHES.**
- Adjust to desired flame.

Closedown

- Close torch valves according to the manufacturer's instructions.
- Close fuel gas cylinder valve.
- Close oxygen cylinder valve.
- Drain fuel gas cylinder line by opening torch fuel gas valve briefly. Close valve. Drain oxygen line in the same way.
- Re-open both torch valves.
- Release pressure adjusting screws on both regulators.

Regulators and torches can now be disconnected.

SILVER SOLDER BRAZING

Silver solder brazing is used for joining metals and steel and dissimilar metal combinations where it is necessary to perform the joining of these metals at low temperatures. Applications include medical and laboratory systems, refrigeration, aerospace, and electronic equipment. In brazing, the major hazards are heat, chemicals, and fumes.

Fumes generated during brazing can be a serious hazard. Brazing fluxes generate fluoride fumes when heated. Cadmium in silver brazing alloys vaporizes when overheated and produces cadmium oxide, a highly toxic substance. Cadmium oxide fumes inhaled into the respiratory tract can cause pulmonary distress, shortness of breath, and in cases of severe exposure may cause death.

The most serious cause of cadmium oxide fumes is overheating the silver brazing filler metal. Care must be taken to control the temperature of the silver brazing operation. The torch flame should never be applied directly to the silver brazing filler rod. The heat of the base metal should be used to melt and flow the brazing filler metal.

Cadmium-plated parts can be an even more hazardous source of cadmium fumes, since in brazing these parts the torch flame is applied directly to the base metal. Cadmium plating should be removed before heating or brazing. When in doubt about a base metal, check with the supplier of the part.

Safe Silver Solder Brazing

- Do not heat or braze on cadmium-plated parts.
- Read warning labels on filler metals and fluxes and follow instructions carefully.
- Work in a well-ventilated area or use a supplied-air respirator.
- Apply heat directly to the base metal—not to the brazing filler metal.
- Do not overheat either the base metal or the brazing filler metal.
- Wash hands thoroughly after handling brazing fluxes and filler metals.

Confined Spaces

Welding in enclosed or confined areas creates additional hazards for the welder. The employer must have a written rescue procedure for confined spaces.

In addition to the procedures outlined in the chapter on confined spaces in this manual, take the following precautions.

- Inspect all electrical cables and connections that will be taken into the confined space.
- Perform leak tests on gas hoses and connections to eliminate the risk of introducing gases into the confined space.
- Check for live electrical systems and exposed conductors.
- Use inspection ports, dipsticks, and the knowledge of plant personnel to evaluate hazards from any liquids, solids, sludge, or scale left in the space.
- Isolate the space from any hydraulic, pneumatic, electrical, and steam systems which may introduce hazards into the confined area. Use isolation methods such as blanks, blinds, bleeding, chains, locks, and blocking of stored energy. Tag isolated equipment.
- A competent person must test and evaluate the atmosphere before workers enter a confined space, and at all times during work there. A hazardous atmosphere may already exist or gases and vapours may accumulate from cutting or welding. Oxygen content may become enriched or depleted.
- Ventilate space with clean air before entry and maintain ventilation as long as necessary to prevent the accumulation of hazardous gases, fumes, and vapours.
- Different gases have different weights and may accumulate at floor, ceiling, or in between. Air monitoring should be done throughout the confined space.
- Keep compressed gas cylinders and welding power sources outside the confined space.
- Where practical, ignite and adjust flame for oxy-fuel applications outside the space, then pass the torch inside. Similarly, pass the torch outside the space, then extinguish it.
- When leaving a confined space, remove the torch and hoses and shut off gas supply.
- If adequate ventilation cannot be maintained, use a suitable supplied-air respirator.

It is the responsibility of the employer to have a written **emergency rescue plan** and communicate the plan to all involved. Each person should know what to do to and how

to do it quickly. (See the Confined Spaces chapter in this manual.)

Personal Protective Equipment

In addition to the protective equipment required for all construction workers (see chapters on personal protective equipment in this manual), welders should wear flame-proof gauntlet gloves, aprons, leggings, shoulder and arm covers, skull caps, and ear protection.

Clothing should be made of non-synthetic materials such as wool. Woollen clothing is preferable to cotton because it is less likely to ignite. Keep sleeves rolled down and collars buttoned up. Wear shirts with flaps over pockets and pants with no cuffs. Remove rings, watches, and other jewelry. Never carry matches or lighters in pockets. Clothing should be free from oil and grease.

Wear high-cut CSA grade 1 footwear laced to the top to keep out sparks and slag.

Protective screens or barriers should be erected to protect people from arc flash, radiation, or spatter. Barriers should be non-reflective and allow air circulation at floor and ceiling levels. Where barriers are not feasible or effective, workers near the welding area should wear proper eye protection and any other equipment required.

Signs should be posted to warn others of welding hazards.

EYE AND FACE PROTECTION

Welding helmets provide radiation, thermal, electrical, and impact protection for face, neck, forehead, ears, and eyes. Two types are available—the stationary plate helmet and the lift-front or flip-up plate helmet.

The lift-front type should have a fixed impact-resistant safety lens or plate on the inside of the frame next to the eyes to protect the welder against flying particles when the front is lifted. All combination lenses should have a clear impact-resistant safety lens or plate next to the eyes.

There are also special models incorporating earmuff sound arrestors and air purification systems. Special prescription lens plates manufactured to fixed powers are available for workers requiring corrective lenses.

The typical lens assembly for arc welding is shown in Figure 16.

The filtered or shaded plate is the radiation barrier. It is necessary to use a filter plate of the proper lens shade to act as a barrier to the harmful light rays and to reduce them to a safe intensity. Guidelines for selection are shown in Figure 17.

In addition to common green filters, many special filters are available. Some improve visibility by reducing yellow or red flare. Others make the colour judgment of

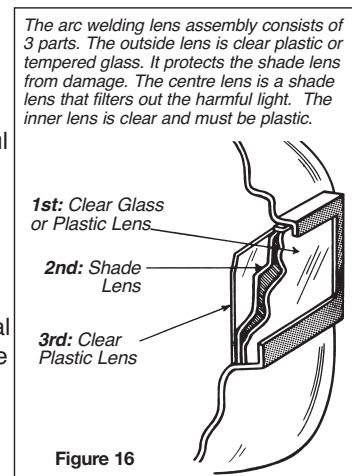

temperature easier. Some have a special gold coating on the filter lens to provide additional protection by reflecting radiation.

Welding hand shields are designed to provide radiation and impact protection for the eyes and face. They are similar to welding helmets except that there are no lift-front models.

Spectacles with full side shields designed to protect against UV radiation and flying objects and suitable filter lenses should always be worn in conjunction with full welding helmets or welding hand shields.

Where only moderate reduction of visible light is required (for instance, gas welding) use eyecup or cover goggles with filter lenses for radiation protection. Goggles should have vents to minimize fogging and baffles to prevent leakage of radiation into the eye cup.

Welders should not wear contact lenses because airborne dust and dirt may cause excessive irritation of the eyes under the lenses.

Lens Shade Selection Guide for Welding

Shade numbers are given as a guide only and may be varied to suit individual needs.

Operation	Electrode Size mm (32nd in.)	Arc Current (Amperes)	Minimum Protective Shade	Suggested ¹
				Shade No. (Comfort)
Shielded Metal Arc Welding (SMAW)	less than 2.5 (3)	less than 60	7	–
	2.5-4 (3-5)	60-160	8	10
	4-6.4 (5-8)	>160-250	10	12
	more than 6.4 (8)	>250-550	11	14
Gas Metal Arc Welding and Flux Cored (GMAW)		less than 60	7	–
		60-160	10	11
		>160-250	10	12
		>250-500	10	14
Gas Tungsten Arc Welding (GTAW)		less than 50	8	10
		50-150	8	12
		>150-500	10	14
Air Carbon (light) Arc Cutting (heavy)		less than 500	10	12
		500-1000	11	14
Plasma Arc Welding (PAW)		less than 20	6	6 to 8
		20-100	8	10
		>100-400	10	12
		>400-800	11	14
Plasma Arc Cutting (PAC)	Light ²	less than 300	8	9
	Medium	300-400	9	12
	Heavy	>400-800	10	14
Torch Brazing (TB)		–	–	3 or 4
Torch Soldering (TS)		–	–	2
Carbon Arc Welding (CAW)		–	–	14
Gas Welding (GW)	Plate Thickness			
		mm	in.	
	Light	under 3.2	under 1/8	4 or 5
	Medium	3.2 to 13	1/8 to 1/2	5 or 6
Heavy	over 13	over 1/2	6 to 8	
Oxygen Cutting (OC)	Light	under 25	under 1	3 or 4
	Medium	25 to 150	1 to 6	4 or 5
	Heavy	over 150	over 6	5 or 6

Figure 17

¹ Shade numbers are given as a general rule. It is recommended to begin with a shade that is too dark to see the weld zone. Then one should go to a lighter shade which gives sufficient view of the weld zone without going below the minimum. In gas welding or oxygen cutting where the torch produces a high yellow light, it is desirable to use a filter lens that absorbs the yellow or sodium line in the visible light of the operation (spectrum).

² These values apply where the actual arc is clearly seen. Experience has shown that light filters may be used when the arc is hidden by the workpiece.

Reproduced with the permission of the American Welding Society.

HEARING PROTECTION

See the Hearing Protection chapter in this manual. Welders may find that ear muffs are cumbersome and interfere with the welding helmet. Ear plugs may be a better choice but must be properly inserted to ensure protection.

Welders should have their hearing checked every year or so. A simple test can be arranged through your doctor. Once hearing is damaged, the loss is likely permanent. Checkups can detect any early losses and help you to save your remaining hearing.

Radiographic and X-Ray Testing

Some construction trades will encounter situations in which welds, metals, or special coatings require onsite non-destructive testing.

Methods include

- 1) radiography using a radioactive source for general materials
- 2) x-rays for testing thicker sections.

Radiography is federally regulated across Canada by the Atomic Energy Control Board. Users must be licensed and operators must be trained according to a Canadian Government Standards Board (CGSB) program.

X-ray testing is provincially regulated—in Ontario by Regulation 632/86.

While many requirements apply to licensed users in both situations, this section will only cover the basic health and safety guidelines for field use.

RADIOGRAPHIC TESTING

Licensed users of radiographic testing systems are responsible for general safety in the field, transportation, emergency procedures, and record-keeping.

Radiographic testing must be carried out in the presence of persons certified to CGSB Standard 48GP4a. In general, these people are employees of a recognized testing agency.

Radiographic materials and equipment must be kept locked up in shielded storage containers accessible only to certified personnel. The containers must be conspicuously marked and kept in an area not normally occupied by the workforce. There may be other special requirements which apply, depending on the strength of the radioactive source and the location.

Radiographic cameras in the field must be used in conjunction with pocket dosimeters, survey meters, directional shields, barrier ropes, radiographic warning signs, and an emergency source container.

General Safety Precautions

- Radiographic testing should be conducted, whenever possible, on an off-shift with as few workers as possible in the work area. The radiographic source should be no stronger than is required for the job. Determining the strength of the source is not generally the responsibility of construction site personnel.
- Equipment should be checked before use. The regulation includes a list of items to be checked, but doing so is not usually the responsibility of site personnel.
- After taking tests where the camera will be moved, the area should be checked using a survey meter.
- Licensed users are required to keep records regarding the use of sources, including dates, times, locations, and other details. These records must be made available to inspectors from the Atomic Energy Control Board. Users are also responsible for advising the local fire department when radioactive material will be in a municipality for longer than 24 hours.

Specific requirements for radiographic camera users are the responsibility of the certified persons operating the equipment.

- The survey meter must be checked to ensure that it is working and calibrated properly.
- Barrier ropes should be set up around the area where testing will be carried out unless this area is isolated and access can be controlled. Barriers must be set up according to the strength of the source.
- Warning signs must be posted along the barriers.
- A patrol must be provided to ensure that no unauthorized persons enter the testing area.
- Before the camera shutter is opened and testing is conducted, the area must be properly shielded.
- Personnel working within the testing area should carry personal dosimeters. Dosimeters may also be advisable for workers in the immediate vicinity outside the barriers.

X-RAY TESTING

Certain basic health and safety precautions are required for the x-ray testing of welds and metals.

- There must be suitable means to prevent unauthorized persons from activating the equipment.
- There must be some device to indicate when the x-ray tube is energized.
- The housing must adequately shield the equipment operator.
- Employers using x-ray equipment must advise the Ministry of Labour that they have such equipment.
- Employers must designate certain persons to be in charge of x-ray equipment who are trained and competent to do so, and must give the Ministry of Labour the names of these designated persons.

Measures and procedures at the x-ray testing site are similar to those required for radiographic testing. The following are the employer's responsibilities.

- Test during off-shifts.
- Cordon off the test area if it cannot be isolated or if entry cannot be controlled.

- Post warning signs along the barrier or at the entrance to the room where testing is taking place.
- Have a patrol to prevent unauthorized entry.
- Install shielding as required before any equipment is activated.
- Ensure that employees in the controlled area wear personal dosimeters.
- Keep dosimeter records.
- Keep at least one radiation survey meter of a suitable type with each portable x-ray machine and calibrate it at least once each year.

Training

Welders, fitters, and welding supervisors should be trained in both the technical and safety aspects of their work. Health and safety training should include but not be limited to the following:

- hazard identification
- safe welding, brazing, and cutting practices
- fire and safety precautions
- control methods for welding hazards
- use, maintenance, and limitations of personal protective equipment.

The effectiveness of health and safety training should be periodically evaluated through

- a workplace inspection to ensure that safe working procedures, equipment, and conditions are implemented
- air monitoring of common contaminants to determine the effectiveness of controls and compliance with acceptable limits
- an assessment of control performance (for instance, testing of the ventilation system)
- review of lost-time-injuries
- discussion of the program with the health and safety committee or representative(s).

Any corrective actions necessary should be taken immediately.